



External Pipe Shot blast

Product Catalog



Pipe External Shot blast

External Pipe Shot blast

PAXAA designs & manufactures fully automated Pipe blasting machines for surface preparation, profiling, removing dust & mill scale from steel pipe.

The purpose for pipe blasting is to prepare or clean the steel surface or substrate for subsequent protective coatings applications such as pre-treatment for painting, tar or PE coating, using (predominantly) steel grit & shot blast media to achieve the desired cleanliness and anchor profile required to achieve acceptable coating adhesion. Depending upon the coating specifications required, 40-100 micron surface profile depth can be easily performed. Pipes can also only be blast cleaned alone, immediately prior to load out removing the majority of internal surface corrosion prior to pipe welding either on or offshore.

Blasting Equipment Line-up

Four blast machine layouts are common in pipe and tube fabricating:

Skew roll machines (Diablo). Angled V-rolls convey and rotate pipe through the blast cabinet, presenting the parts to the blast wheels several times in the process.



The blast wheels are located on the roof of the cabinet. This type of machine is useful for tube, bar stock, and pipe diameters up to 600 mm.

Multi-bar machines. Small-diameter bar is conveyed in multiple lines through the blast cabinet. The bar is not skewed as it is conveyed, and passes through without rotating. Therefore, multiple wheels must be positioned around the part to propel blast media at the bar at varying angles.

Up-blast pipe machines. These machines feature blast wheels located below the pipe as it passes through the blast cabinet. This means the distance between part and blast wheel is constant, regardless of pipe diameter. This machine can accommodate pipe diameters in excess of 1500 mm.



Pipe External Shot blast

Down-blast pipe machines. This machine type is similar to the up-blast machine, with the crucial difference being that the blast wheels are positioned on the roof of the cabinet. This means that the distance between parts and blast wheels varies as the part diameter varies. The maximum part diameter should not exceed 900 to provide repeatable results.

PAXAA works with customers to determine the requirements and will consider many factors, including:

- Steel abrasive types
- Profile requirements
- Surface cleaning requirement
- Line speed requirement

As well as working closely with coating manufacturers to assure proper mill profile is achieved to give the best adherence of coating.

All PAXAA systems are capable of a standard cleanliness value of SIS S.A. 2.5/ ISO 8501-1, SSPC-SP 10/ NACE No.2, near white metal cleanliness, or a SIS S.A. 3/ ISO 8501-1S, SSPC-SP 5/NACE No. 1, white metal cleanliness, when required for certain applications / specifications.

Principle:

The pipe is conveyed through the blast machine on a specially designed external skew roll type material handling system. An extensive range of high production blast cabinets are available to handle from 150mm to 2500mm diameter pipe at variable cleaning speeds.

PAXAA pipe machines include an air wash and dust collection system that work together to remove contaminants and fines, control dust and maintain correct abrasive size.





Pipe External Shot blast

Up-blast Pipe Shot blast

The PAXAA up-blast pipe machine is a fully automated system designed to remove rust and scale from steel pipe. The pipe is conveyed through the blast machine on a specially designed external skew roll type material handling system.

An extensive range of high production blast cabinets are available to handle from 250mm to 2500mm diameter pipe at variable cleaning speeds.

PAXAA products include standard and customized systems to meet individual customer requirements.

Features and benefits:

- Robust design with low operation & maintenance cost
- High capacity BW320 & BW520 bi-directional heavy-duty internal blast wheels
- High-capacity abrasive recycling
- High-efficiency dust collector
- Easy removable entry and exit vestibule seals modules for ranges of pipe diameters
- Internal cabinet sections directly impacted with abrasive media are lined with replaceable wear plates
- For ease of shipment, 900mm & 1500mm models are in sled design & 2500mm machines are supplied in modular form

Available options:

- Mechanical or Pulse jet bag filter matched to machine requirements
- Automatic pipe loading & unloading system
- Easy slide-out Blast wheels mounted for ease of service outside the blast machine
- Automatic abrasive adder
- Complete Long-Life cabinet lining
- Additional seal modules
- PLC controls with diagnostic capabilities
- Integration with upstream & downstream of paint application system

Safety features:

- Timed operation between the abrasive control valve and the door
- Limit switch on the loading and rear access door to prohibit the wheel from starting when the door is opened.
- Safety Signs
- Emergency shutdown system.

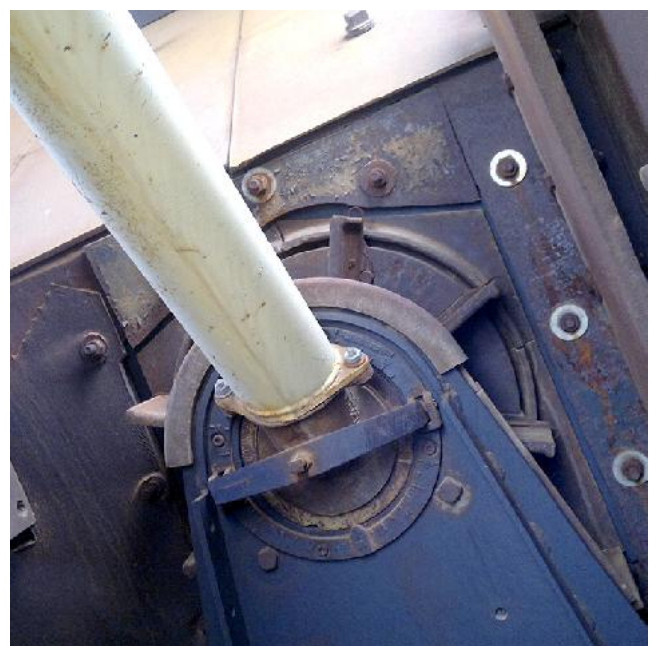



Pipe External Shot blast

Up-blast Pipe Shot blast Technical Data

- Extensive pipe blasting range, 150 mm up to 2500mm
- Standard & customized systems
- Robust design
- Low operation & maintenance cost
- High throughput
- High-efficiency dust collector
- Sled & modular design for easy shipment & installation
- Automatic pipe loading & unloading system
- PLC control & plant Integration
- Several built-in safety features

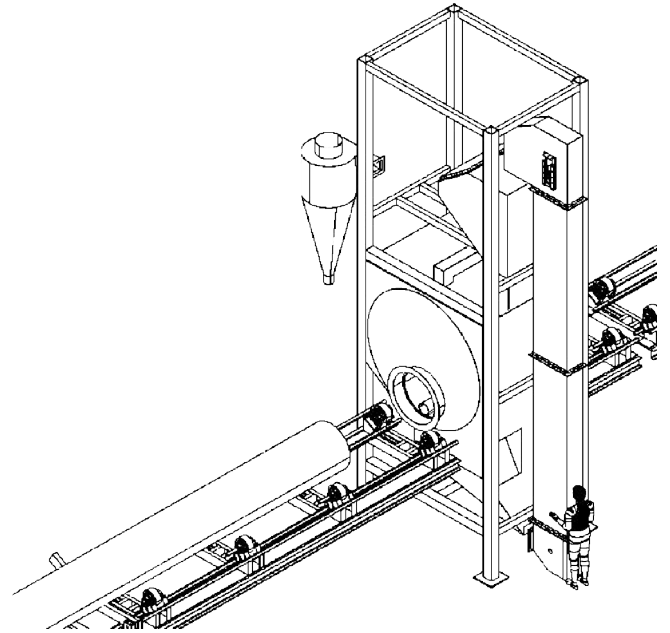

Model Type	PX-PDB9	PX-PUB15	PX-PUB25
Blasting Direction	Down-blast	Up-blast	Up-blast
Maximum pipe diameter	900 mm	1500 mm	2500 mm
Minimum pipe diameter	150 mm	250 mm	
Cabinet	Mild steel construction		
Vestibule Seals	Seal sets for each diameter pipe		
Lining	Cast premium alloy and manganese rolled steel		
Abrasive Reclaim System	Bucket elevator comes with multi-ply belt with cast buckets		
Abrasive Flow Rate	800 kg/min	1000 kg/min	1500 kg/min
Abrasive Consumption	20-36 kg/hr		
Abrasive Separator	Air-wash & Settlement chamber		
Number of Blast Wheels	2	2	2
Wheel Power	37kW for each wheel	45kW for each wheel	60kW for each wheel
Blasting Capacity (SA2.5)	2.5-5 m ² /min		
Pass line Height	750-900 mm		
Conveyor speed	0.4-2.5 m/min (with variable speed drive)		
Pipe Pivot loader/unloader	Mechanical and or hydraulic operation		
Dust Collector	High Efficiency Cyclone & Mechanical Shaker or Pulse jet Bag filter system		
Air conveying system capacity	20000 to 36000 m ³ /h		

Contact PAXAA for more information on parts and services for your wheel blast equipment.

PAXAA

General Machinery Design & Manufacturing

Address: UNIT 2 , NO 20, Arooji ST,
North Kargar ST, Tehran, IRAN

Tel: +98 21 6696 0783, Fax: +98 21 6696 0784

www.paxaa.com

paxaa@paxaa.com



PAXAA
پکصا